

Fisher-Price®

Model L5805

Super Sounds Soccer™



PARTS

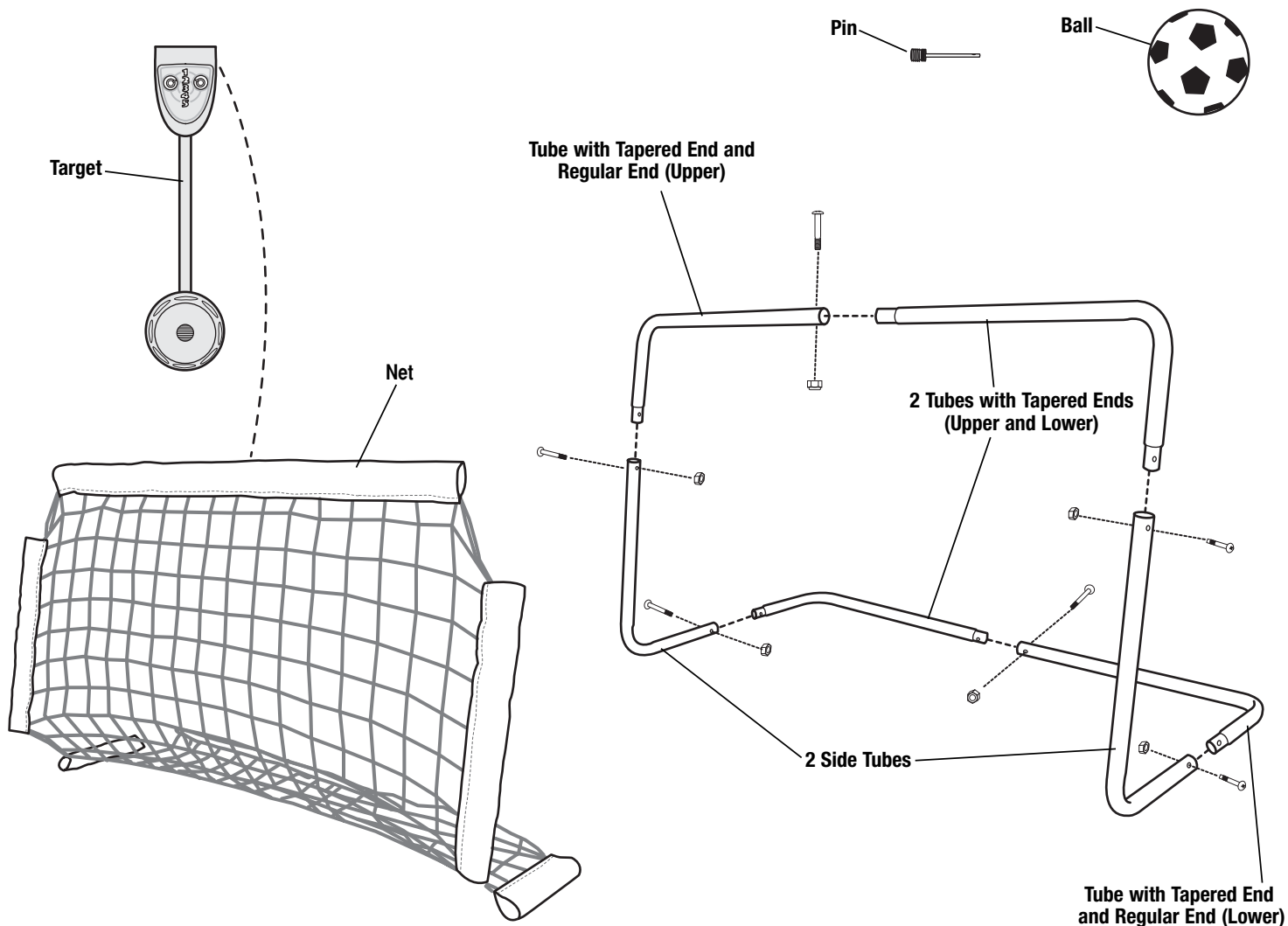

- Please keep this instruction sheet for future reference, as it contains important information.
- Adult assembly is required.
- Tool needed for assembly: Phillips Screwdriver (not included).
- Hand pump (not included) and inflation pin (included) required to inflate the soccer ball.
- Requires three “AAA” (LR03) **alkaline** batteries (not included) for operation.
- Please remove all parts from the package and identify them before assembly.

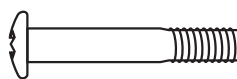

M5 x 28 mm Screw



M5 Lock Nut

BOTH SHOWN ACTUAL SIZE

Note: Tighten and loosen all screws with a Phillips Screwdriver. Do not over-tighten the screws.

ASSEMBLY

CAUTION

This product contains small parts in its unassembled state. Adult assembly is required.

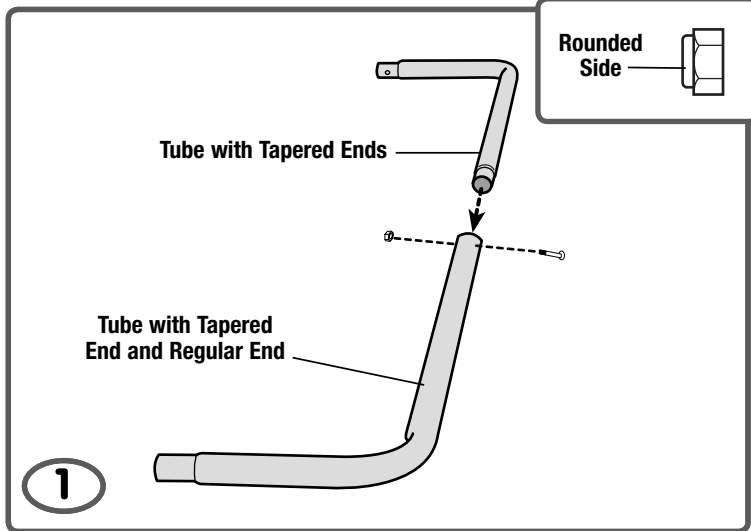

- Place a tube with tapered end and regular end on a flat surface.
- Fit a tube with tapered ends into the regular end, as shown.

Hint: The tube assembly should form this shape .

- Align the holes in the tubes.
- Fit a lock nut, rounded side out, into the **hex hole on the inside** of the tube with tapered end and regular end.
- Insert a screw through the outside of the tube with tapered end and regular end.
- While holding the lock nut in place, tighten the screw.

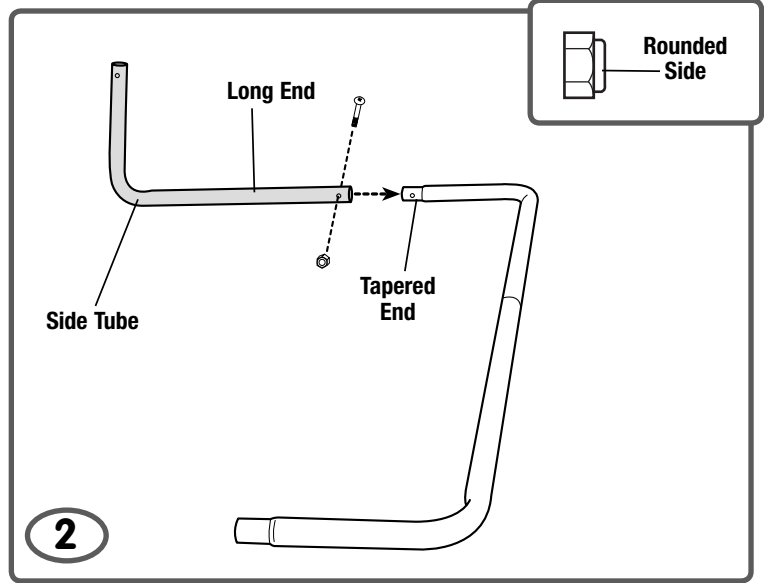

- Fit the long end of a side tube onto either tapered end of the assembly.
 - Align the holes in the two tubes.
- Hint:** If the holes in the tubes do not align, remove the side tube and place it on the other end of the assembly.
- Fit a lock nut, rounded side out, **into the hex hole in the inside** of the side tube.
 - Insert a screw through the hole on the outside of the side tube.
 - While holding the lock nut in place, tighten the screw.

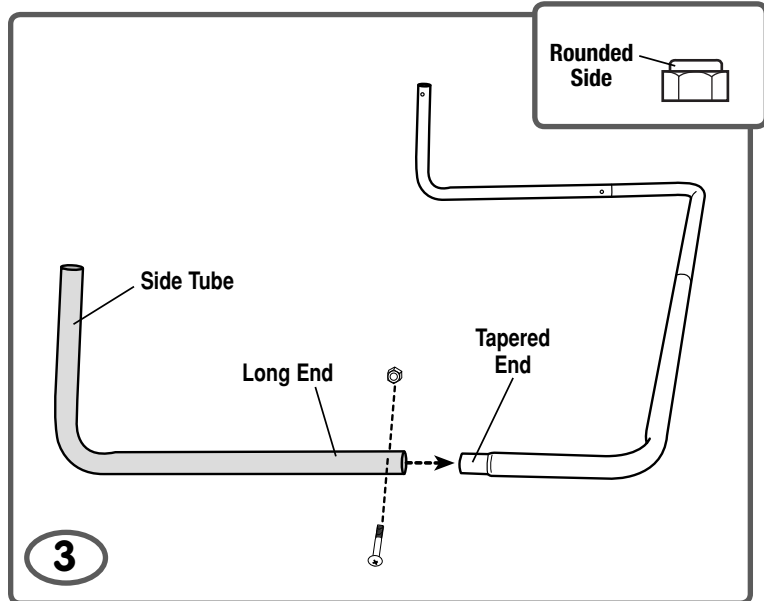

- Fit the long end of the other side tube onto the other tapered end of the assembly.
- Align the holes in the two tubes.
- Fit a lock nut, rounded side out, into the **hex hole on the inside** of the side tube.
- Insert a screw through the hole on the outside of the side tube.
- While holding the lock nut in place, tighten the screw.

ASSEMBLY

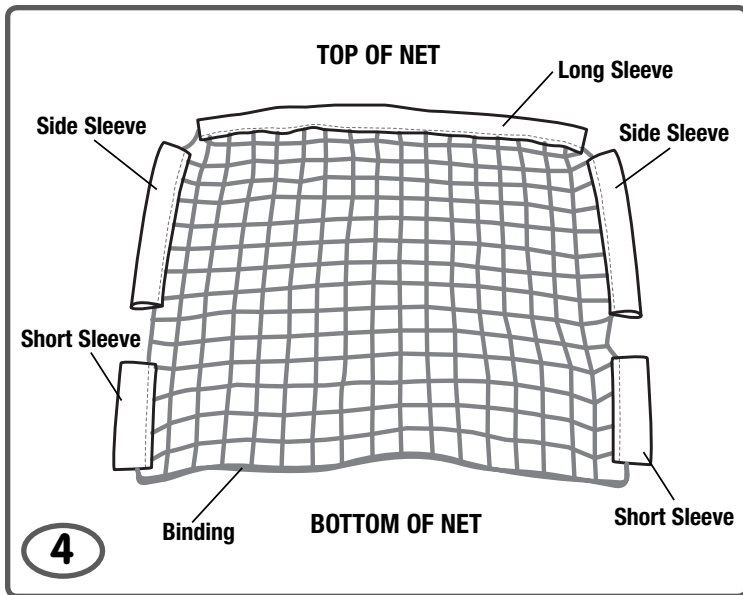

- Lay the net on a flat surface.
- **Note** the long sleeve, two side sleeves and two short sleeves on the net.
 - Long sleeve is the top of the net.
 - Binding is the bottom of the net.

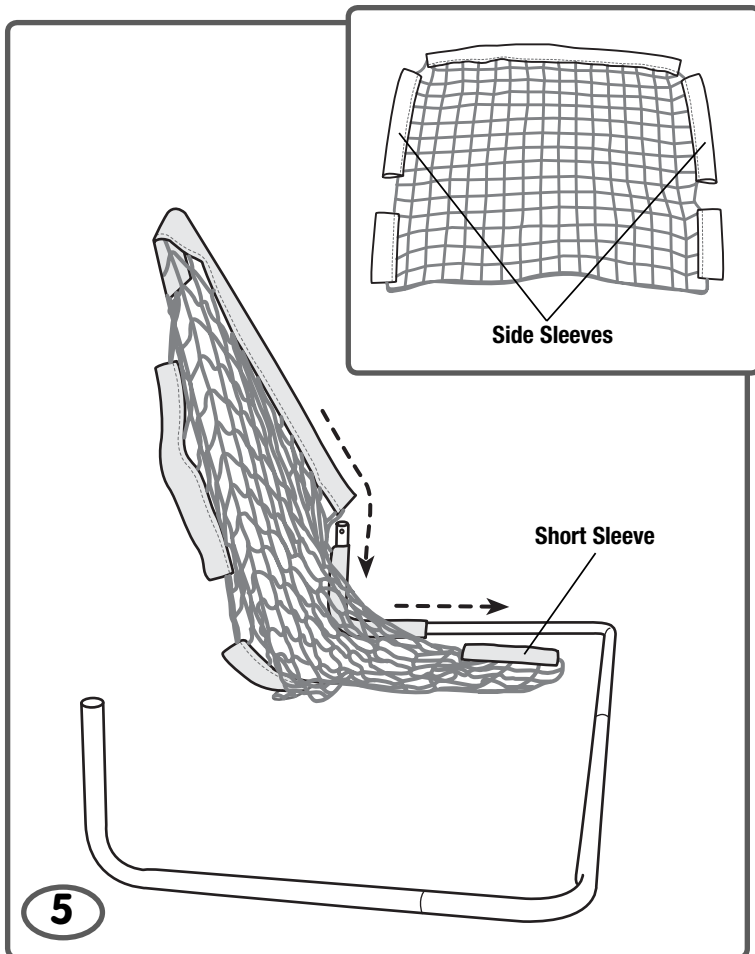

- Locate the side sleeves on the sides of the net.
- First, fit the side sleeve onto the side tube.
- **Note:** The short sleeve should **not** be fitted onto the tube.

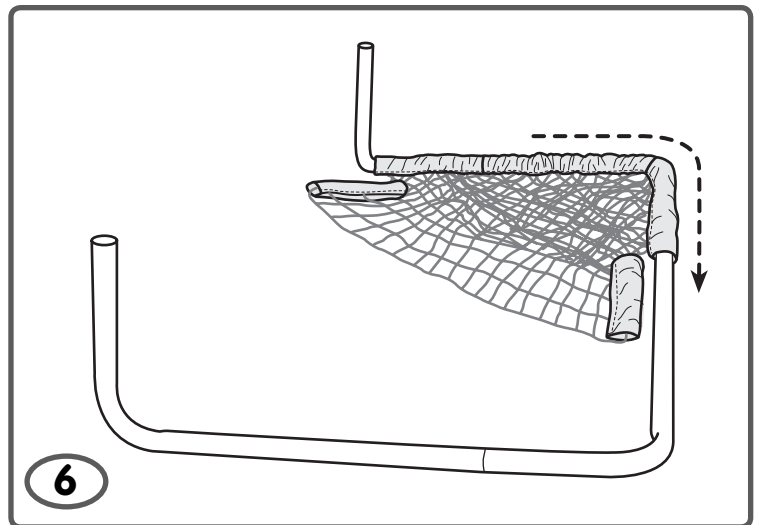

- Next, fit the long sleeve and other side sleeve on to the side tube.
- **Note:** The short sleeve should **not** be fitted onto the tube.

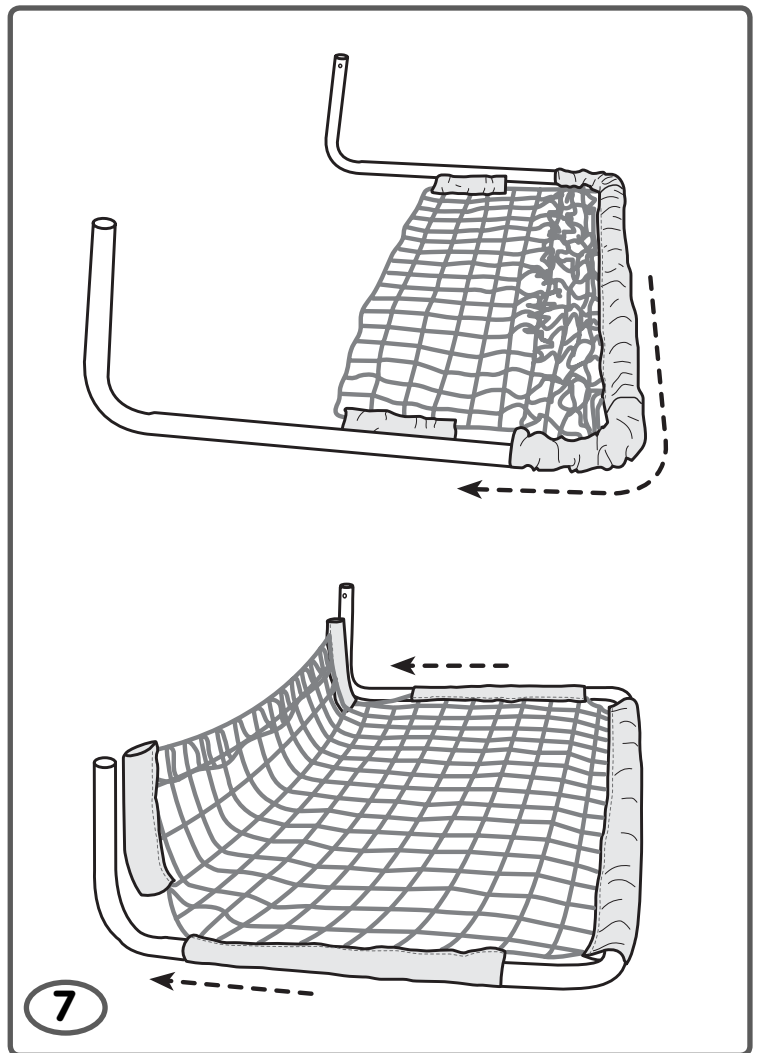

- Slide the sleeves and the net evenly around the frame, as shown.

ASSEMBLY

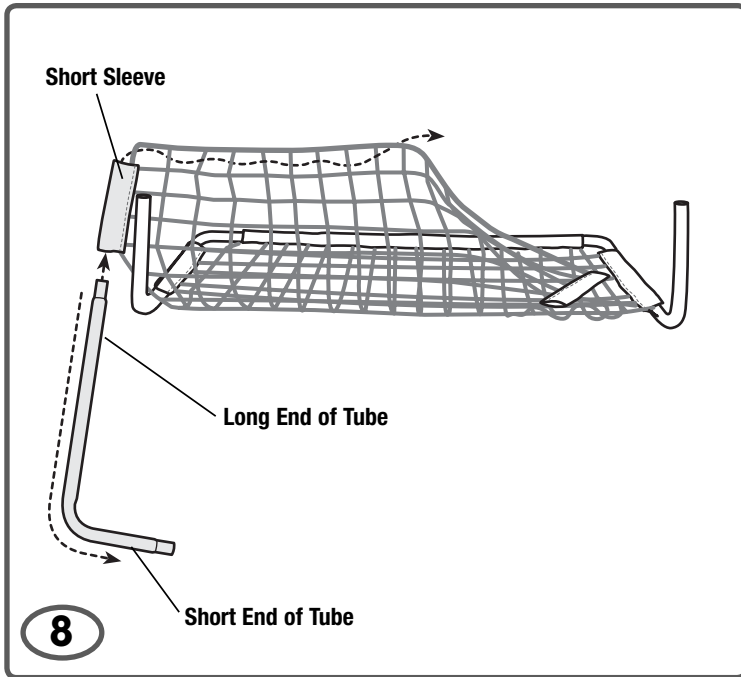

- Fit the long end of either remaining tube through the short sleeve.
- Now, weave the tube through the openings on the edge of the net (about half way).

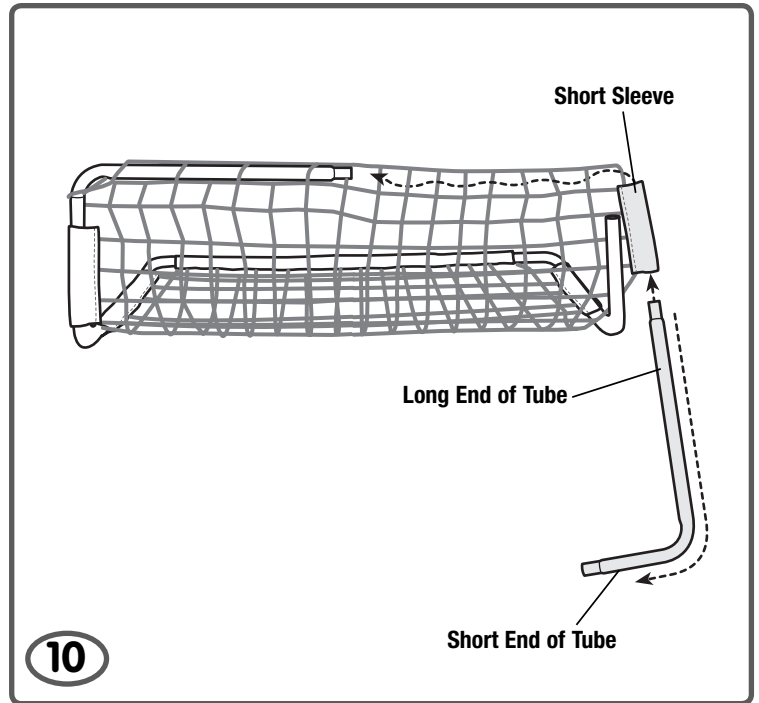

- Fit the long end of the remaining tube through the short sleeve and weave the tube through the openings on the edge of the net.

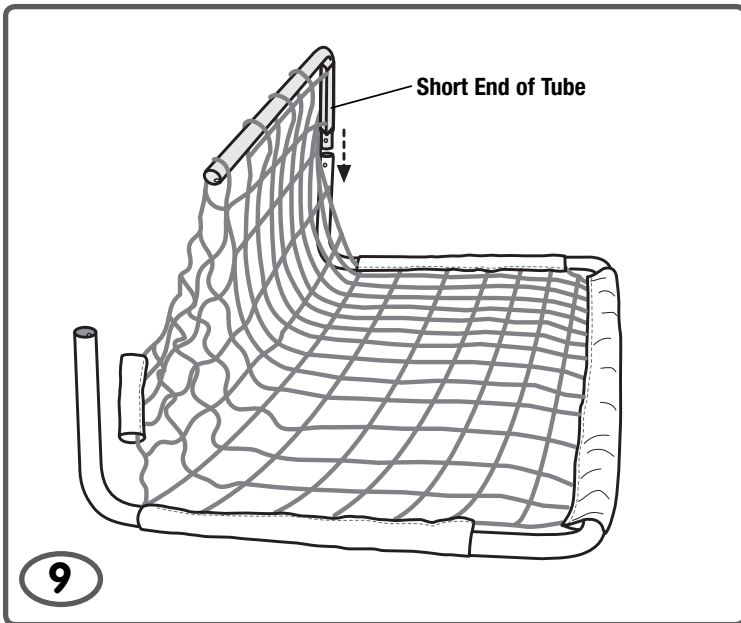

- Fit the short end of the tube into the frame assembly.

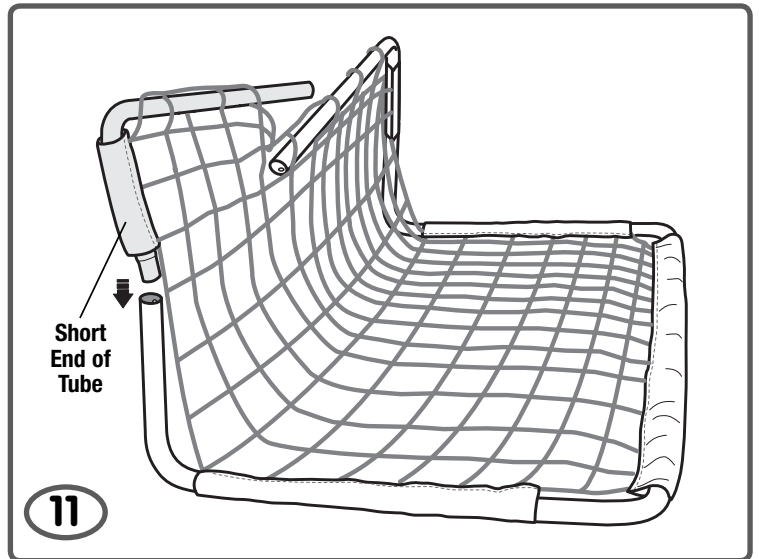

- Fit the short end of the tube into the frame assembly.

ASSEMBLY

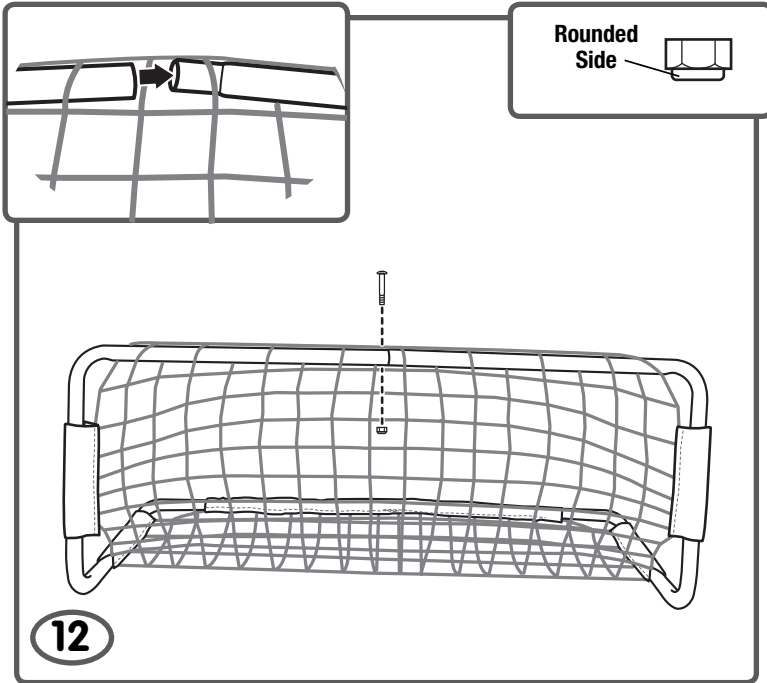

12

- Fit the ends of the tubes together.
- Fit a lock nut, rounded side out, into the **hex hole on the inside** of the tube assembly.
- Insert a screw through the hole in the outside of the tube assembly.
- While holding the lock nut in place, tighten the screw.

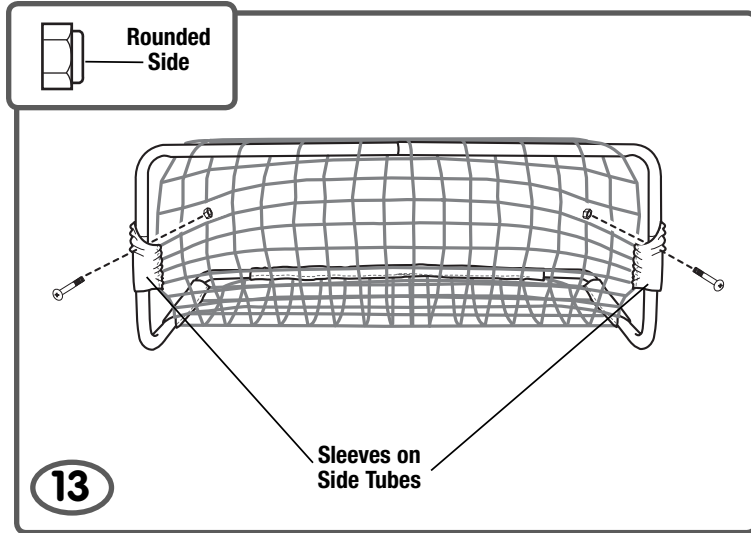

13

- Push the net sleeves down on the side tubes.
- Fit two lock nuts, rounded side out, into the **hex hole in the inside** of each side tube assembly.
- Insert a screw into the outside hole in each side tube assembly.
- While holding the lock nut in place, tighten the screw. Repeat this procedure to fasten the other screw.

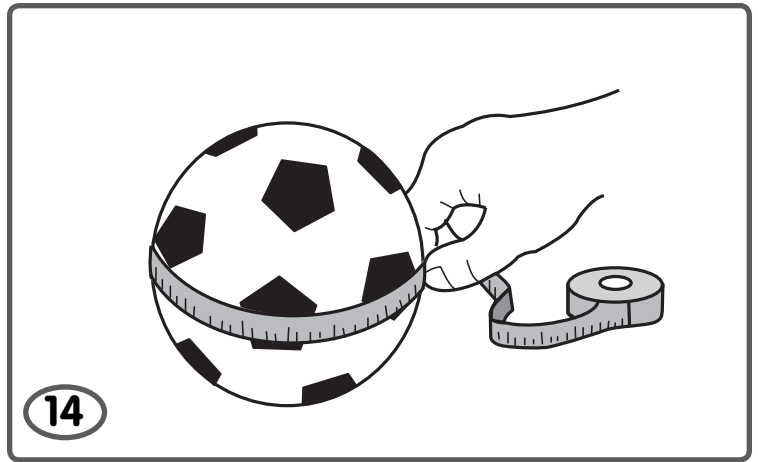

14

- Insert the inflation pin into the ball.
- Attach the pump (not included) to the pin.
- Inflate the ball to a circumference of 15 1/2" (39 cm), until firm. Do not over-inflate.
- After inflating the ball, remove the pin. Store the pin out of the reach of children for future use.

Assembly is now complete.

BATTERY INSTALLATION

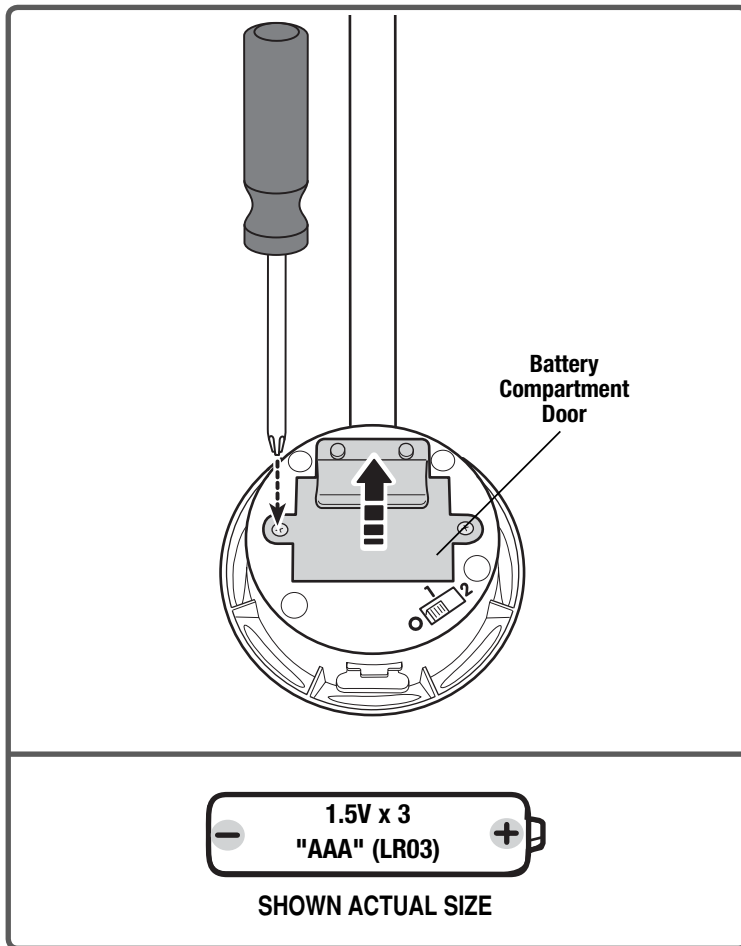

- Loosen the screws in the battery compartment door and remove the battery compartment door.
 - Insert three “AAA” (LR03) **alkaline** batteries into the battery compartment.
- Hint:** We recommend using **alkaline** batteries for longer battery life.
- Replace the battery compartment door and tighten the screws.
 - When sound becomes faint or there is no sound at all, it’s time for an adult to replace the batteries!

 Protect the environment by not disposing of this product with household waste (2002/96/EC). Check your local authority for recycling advice and facilities (Europe only).

BATTERY SAFETY INFORMATION

In exceptional circumstances, batteries may leak fluids that can cause a chemical burn injury or ruin your product. To avoid battery leakage:

- Do not mix old and new batteries or batteries of different types: alkaline, standard (carbon-zinc) or rechargeable (nickel-cadmium).
- Insert batteries as indicated inside the battery compartment.
- Remove batteries during long periods of non-use. Always remove exhausted batteries from the product. Dispose of batteries safely. Do not dispose of the product in a fire. The batteries inside may explode or leak.
- Never short-circuit the battery terminals.
- Use only batteries of the same or equivalent type, as recommended.
- Do not charge non-rechargeable batteries.
- Remove rechargeable batteries from the product before charging.
- If removable, rechargeable batteries are used, they are only to be charged under adult supervision.

BEGINNER

Beginner's score fun sounds when the ball hits the net!

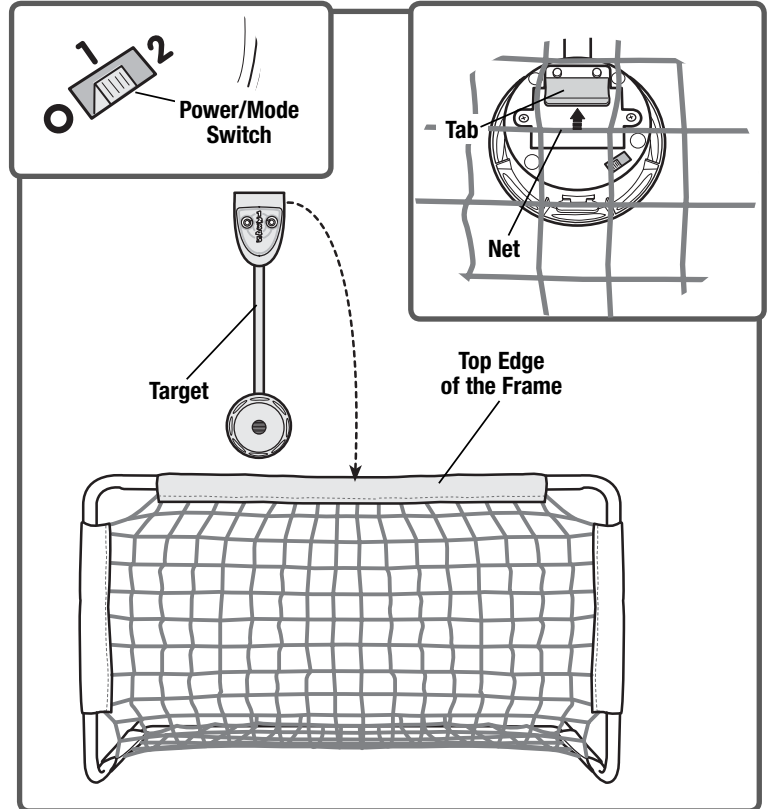

- Locate the power/mode switch on the back of the target. Slide the switch to **1** for beginners.
- Fit the target onto the top edge of the frame.
- Fit the tab on the back of the target onto a net loop.

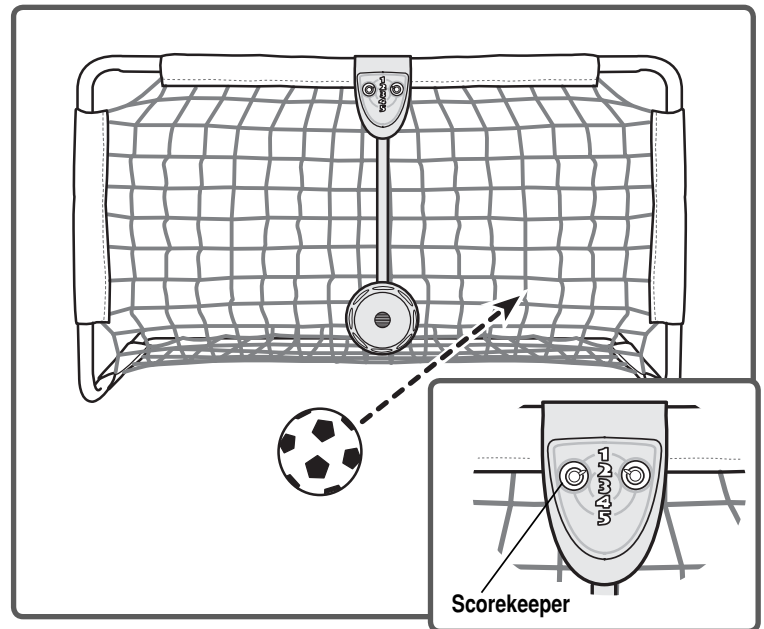

- Your little player hears fun sounds each time the ball hits the net.
- Turn the knob on the scorekeeper to record your goal!
- When you're finished playing, slide the power/mode switch on the target to the **0** off position.

PRO

Hit the target like a pro for fun sounds!

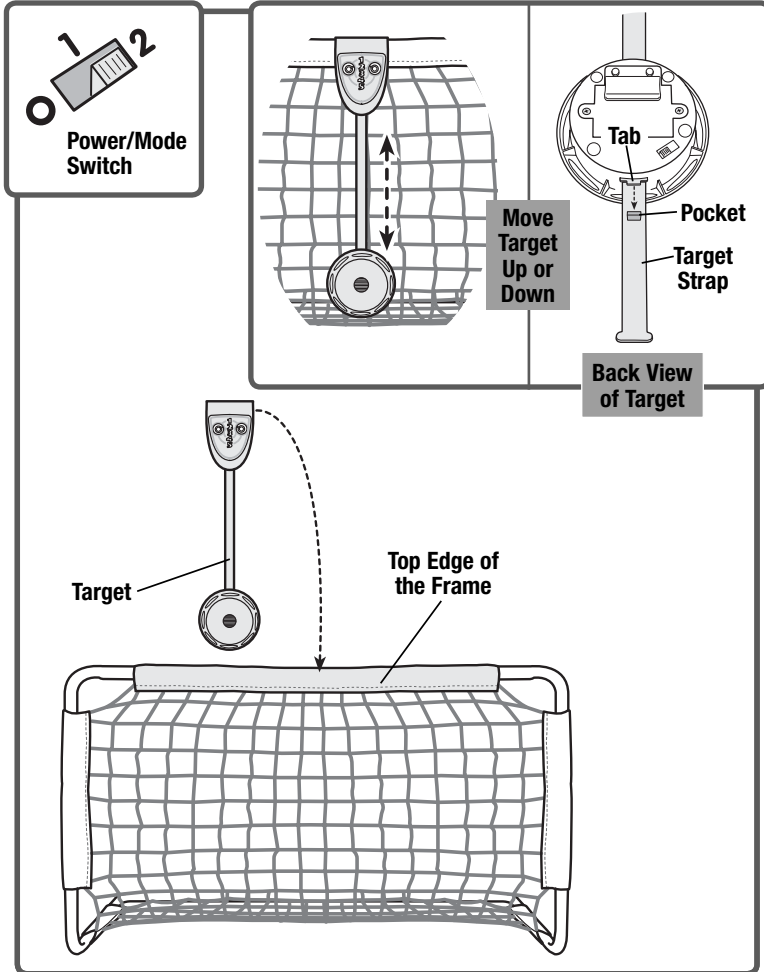

- Locate the power/mode switch on the back of the target. Slide the switch to **2** for more advanced players.
- Fit the target onto the top edge of the frame.

Hint: You can raise or lower the target. Push the target up or down into any of three positions and secure it by inserting the tab on the back of the target into the pockets on the back of the target strap.

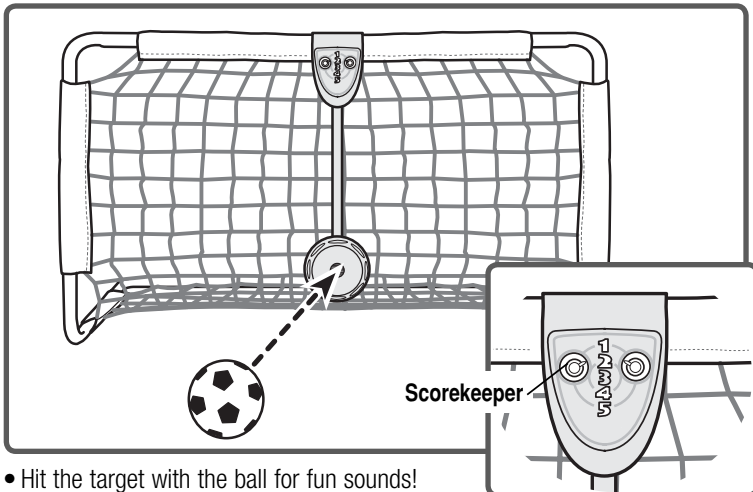

- Hit the target with the ball for fun sounds!
- Turn the knob on the scorekeeper to record your goal!
- When you're finished playing, slide the power/mode switch on the target to the **0** off position.

CONSUMER INFORMATION

CARE

- The frame and net may be wiped clean using a mild cleaning solution and a damp cloth. Do not use bleach. Do not use harsh or abrasive cleaners. Rinse clean with water to remove residue. Do not immerse this toy.
- To prolong the life of the net, store this toy indoors.
- Periodically check all fasteners regularly to be sure they are tight. If the fasteners are not tight, tighten them as necessary.

QUESTIONS?

Visit us on-line at www.service.fisher-price.com

Call our Consumer Relations Department, toll-free at **1-800-432-5437**, 9 AM - 7 PM EST Monday through Friday and 11 AM - 5 PM EST Saturday. Hearing-impaired consumers using TTY/TDD equipment, please call 1-800-382-7470. Write to us at: Fisher-Price® Consumer Relations, 636 Girard Avenue, East Aurora, New York 14052.

FCC STATEMENT (UNITED STATES ONLY)

This equipment has been tested and found to comply with the limits for a Class B digital device, pursuant to Part 15 of the FCC Rules. These limits are designed to provide reasonable protection against harmful interference in a residential installation. This equipment generates, uses and can radiate radio frequency energy and, if not installed and used in accordance with the instructions, may cause harmful interference to radio communications. However, there is no guarantee that interference will not occur in a particular installation. If this equipment does cause harmful interference to radio or television reception, which can be determined by turning the equipment off and on, the user is encouraged to try to correct the interference by one or more of the following measures:

- Reorient or relocate the receiving antenna.
- Increase the separation between the equipment and receiver.
- Consult the dealer or an experienced radio/TV technician for help.

Note: Changes or modifications not expressly approved by the manufacturer responsible for compliance could void the user's authority to operate the equipment.

For countries outside the United States:

CANADA: Questions? 1-800-432-5437. Mattel Canada Inc., 6155 Freemont Blvd., Mississauga, Ontario L5R 3W2; www.service.mattel.com.

GREAT BRITAIN: Mattel UK Ltd, Vanwall Business Park, Maidenhead SL6 4UB. Helpline: 01628 500303; www.service.mattel.com/uk

AUSTRALIA: Mattel Australia Pty. Ltd., 658 Church Street, Locked Bag #870, Richmond, Victoria 3121 Australia. Consumer Advisory Service 1300 135 312.

NEW ZEALAND: 16-18 William Pickering Drive, Albany 1331, Auckland.

ASIA: Mattel East Asia Ltd, Room 1106, South Tower, World Finance Centre, Harbour City, Tsimshatsui, HK, China.